



Bobcat®

T35120SL

Telescopic Handlers



Performance

Lifting height — on tyres	11620 mm
Lifting height — on stabilisers	11850 mm
Rated capacity	3500 kg
Capacity (at max. height on stabilisers)	3200 kg
Capacity (at max. height on tyres)	2300 kg
Capacity (at max. reach on stabilisers)	1200 kg
Capacity (at max. reach on tyres)	350 kg
Max. reach on tyres	8100 mm
Max. reach on stabilisers	8040 mm
Crowding force	4600 daN

Weights

Weight (unladen)	8240 kg
------------------	---------

Traction

Standard tyres	400/70x20 150B
Low speed (forward/reverse)	0–7 km/h
High speed (forward/reverse)	0–30 km/h
Driving modes	Direct drive / soft drive

Drive System

Transmission	Hydrostatic with electronic regulation
Main drive	2-speed hydrostatic motor

Engine

Make / Model	PERKINS / 1104D-44TA Turbo
Fuel / Cooling	Diesel / Water
Rated power (DIN 6271) at 2200 RPM	74.5 kW (100 HP)
Maximum torque at 1400 RPM	410 Nm
Number of cylinders	4
Displacement	4.4 l

Hydraulic System

Pump type	Gear pump with LS valve
Combined pump capacity	135 l/min
Working pressure	265 bar

Cycle Times

Lift time - no load	10.0 s
Lower time - no load	5.5 s
Telescope in time at max. reach - no load	11.5 s
Telescope in time at max. height - no load	11.5 s
Telescope out time at max. reach - no load	13.0 s
Telescope out time at max. height - no load	13.0 s

Brakes

Engine braking	Hydrostatic
Parking and emergency brake	Negative brake with hydraulic command

Fluid Capacities

Axles and reduction gears front / rear	9 / 8.1 l
Engine oil	8.5 l
Fuel tank	140 l
Hydraulic reservoir	77 l

Standard Features

- Aggravating Movements Arrester (AMA)
- Hydrostatic transmission
- ROPS/FOPS operator cab
- Heating, demisting and ventilation
- Front and rear washer/wipers
- Suspension seat
- Two-way hydraulic supply at the end of the boom
- Narrow hook-up for mounting of the equipment
- Mechanical lock of the equipment

Options

- Back-up alarm
- Second hydraulic function on boom
- Cab air conditioning
- Rear hydraulic hook and mirror
- Rotating beacon
- Cooling fan reverser for cleaning purposes
- Rear hydraulic connection
- Trailer brake valve
- Work light on boom
- Set of blue lights for hen houses
- Hydraulic lock of equipment
- Yoke and electrical plug
- Windscreen grill
- Roof windscreen wiper
- Transmission lock override

Load Charts

With forks and TITAN 400/70 x 20 tyres — on tyres

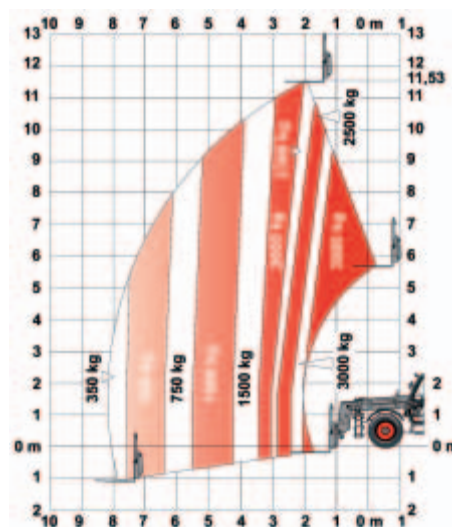

Dimensions

All dimensions in mm.

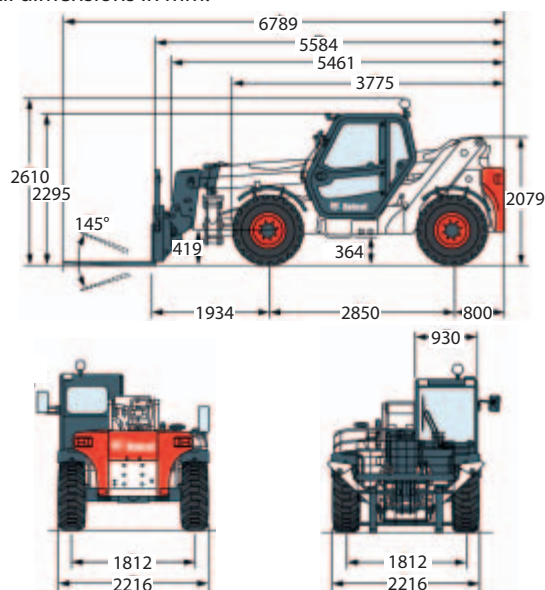

www.bobcat.eu



Bobcat®

Specifications and design are subject to change without notice - Pictures of Bobcat units may show other than standard equipment.

