

# C PS 15

**CLARK**  
THE FORKLIFT

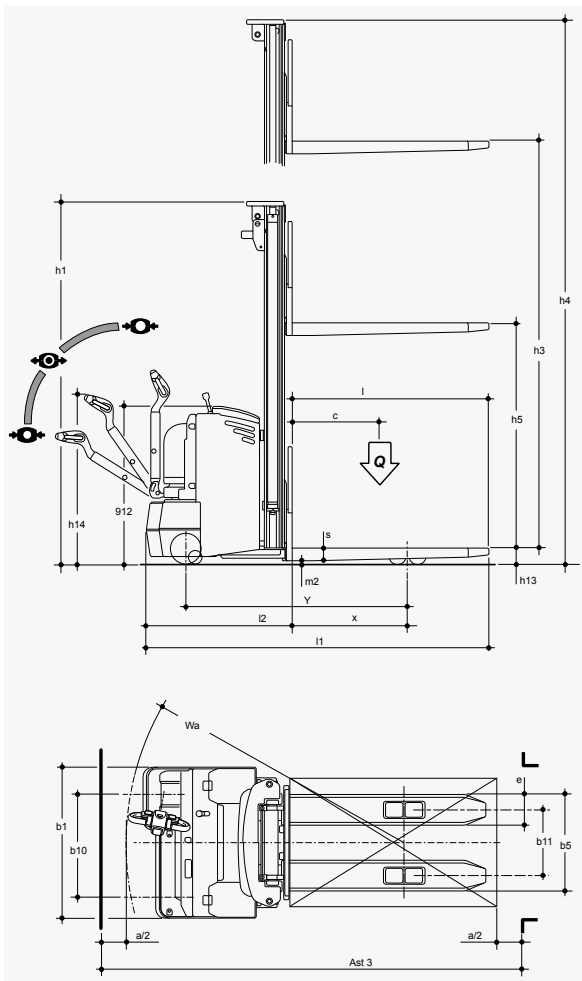

h3		h1	h4	h5	(Q) t
1.650	mm	2.085	2.250	1.565	1.5
2.800	mm	1.955	3.400	1.410	1.5
3.100	mm	2.105	3.700	1.560	1.35
3.600	mm	2.355	4.200	1.810	1.15
3.900	mm	1.855	4.500	1.310	1.0
4.200	mm	1.955	4.800	1.410	0.9
4.650	mm	2.105	5.250	1.560	0.75

## PEDESTRIAN WRAP OVER FORKS STACKER

Characteristics	1.1	Manufacturer			<b>CMHEU</b>
	1.2	Manufacturer's model designation			<b>C PS 15</b>
	1.3	Drive : E ( electric )			<b>E</b>
	1.4	Type of control : T (tiller) S (steering wheel) A (pedestrian) P (standing) R (seated)			<b>T / A</b>
	1.5	Load capacity		<b>Q ( t )</b>	<b>1,5</b>
	1.6	Load centre distance		<b>c ( mm )</b>	<b>600</b>
	1.8	Load distance, centre of drive axle to fork		<b>X ( mm )</b>	<b>660</b>
	1.9	Wheelbase		<b>Y ( mm )</b>	<b>1.330</b>
	Weights	2.1	Service weight ( battery included )		<b>Kg</b>
2.2		Axle loading ( with load )	front / rear	<b>Kg</b>	<b>1.000 / 1.740</b>
2.3		Axle loading ( without load )	front / rear	<b>Kg</b>	<b>848 / 392</b>
Wheels - Chassis	3.1	Tyres : plt ( polyurethane ) vlk ( vulkollan )			<b>plt</b>
	3.2	Front wheels size		<b>mm</b>	<b>245</b>
	3.3	Rear wheels size		<b>mm</b>	<b>85</b>
	3.4	Stabilizers wheels dimensions		<b>mm</b>	<b>150</b>
	3.5	Wheels : number front / rear ( x = traction )			<b>1x + 1 / 2 - 4</b>
	3.6	Front track width		<b>b 10</b>	<b>610</b>
	3.7	Rear track width		<b>b 11</b>	<b>380</b>
Dimensions	4.2	Lowered mast height		<b>h1 ( mm )</b>	<b>2.105</b>
	4.3	Free lift		<b>h5 ( mm )</b>	<b>1.560</b>
	4.4	Lifting height		<b>h3 ( mm )</b>	<b>3.100</b>
	4.5	Extended mast height		<b>h4 ( mm )</b>	<b>3.700</b>
	4.6	Free lift			
	4.9	Height of tiller arm in drive position ( min / max )		<b>h14 ( mm )</b>	<b>840 / 1.230</b>
	4.15	Forks lowered height		<b>h13 ( mm )</b>	<b>90</b>
	4.19	Total length		<b>l1 ( mm )</b>	<b>2.000</b>
	4.20	Length to forks face		<b>l2 ( mm )</b>	<b>850</b>
	4.21	Overall width		<b>b1 / b2 ( mm )</b>	<b>880</b>
	4.22	Forks dimensions		<b>s / e / l</b>	<b>70 / 180 / 1.150</b>
	4.24	Fork carriage width		<b>b3 ( mm )</b>	<b>665</b>
	4.25	Width over forks		<b>b5 ( mm )</b>	<b>560</b>
	4.32	Ground clearance	laden	<b>m2 ( mm )</b>	<b>20</b>
	4.33	Aisle width for pallets 1000 x 1200 forking side 1200		<b>Ast3 ( mm )</b>	
4.34	Aisle width for pallets 800 x 1200 forking side 800		<b>Ast3 ( mm )</b>	<b>2.455</b>	
4.35	Turning radius		<b>Wa ( mm )</b>	<b>1.745</b>	
Performances	5.1	Travel speed	laden / unladen	<b>Km / h</b>	<b>5.8 / 6</b>
	5.2	Lifting speed	laden / unladen	<b>m / s</b>	<b>0.12 / 0.20</b>
	5.3	Lowering speed	laden / unladen	<b>m / s</b>	<b>0.45 / 0.4</b>
	5.7	Gradient performance ( S2 30 min )		<b>%</b>	
	5.8	Max gradient performance ( S2 5 min )		<b>%</b>	<b>6 / 10</b>
	5.10	Service brake M ( mechanical ) I ( hydraulic ) IV ( inversion braking )			<b>IV</b>
El.Motor	6.1	Traction motor, rating S2 60 min		<b>KW</b>	<b>2</b>
	6.2	Lifting motor, rating S3 15%		<b>KW</b>	<b>3</b>
	6.3	Battery according DIN 43531 / 35 / 36 A, B, C, no			<b>no</b>
	6.4	Battery voltage, nominal capacity K5		<b>V / Ah</b>	<b>24 / 300</b>
	6.5	Battery weight ( ± 5 % )		<b>Kg</b>	<b>200</b>
Others	8.1	Type of travel control			<b>MOS DC</b>
	8.4	Sound level at driver's ear		<b>dB ( A )</b>	<b>&lt; 70</b>
<i>Technical specification according to VDI 2198</i>					
<i>Information and dat are given for information only, CMHEU will have the sole right for technical changes and improvements without giving any notice.</i>					



**CLARK MATERIAL HANDLING EUROPE (CMHEU)**

**Neckarstraße, 37  
D-45478 MÜLHEIM an der RUHR  
Tel: +49 (0) 208 377336-0 Fax: +49 (0) 208 377336-36  
www.clarkmheu.com  
info-europe@clarkmheu.com**

Distributed by :