

POWER RATING

Engine Speed rev/min	Type of Operation	Engine Power	
		kWm	Ps
1800	Prime Power	659	896
	Standby Power	711	967
1500	Prime Power	569	774
	Standby Power	612	832

Note : -. The engine performance corresponds to ISO 3046, BS 5514 and DIN 6271.

-. Ratings are based on ISO 8528.

Prime power available at variable load. The permissible average power out put (during 24h period) shall not exceed 70% of the prime power rating.

Standby power should be applied only to provide a basic support function to a building electrical supply in the event of a main power network failure. No overload is permitted.

-. This Rating fulfills EPA exhaust emission regulation Tier-2

MECHANICAL SYSTEM

○ Engine Model	P222FE
○ Engine Type	V-type 4 cycle, water cooled Turbo charged & intercooled (air to air)
○ Combustion type	Direct injection
○ Cylinder Type	Replaceable wet liner
○ Number of cylinders	12
○ Bore x stroke	128(5.04) x 142(5.59) mm(in.)
○ Displacement	21.927 (1,338.0) lit.(in ³)
○ Compression ratio	14.2 : 1
○ Firing order	1-12-5-8-3-10-6-7-2-11-4-9
○ Injection timing	12° BTDC (60Hz) / 9° BTDC (50Hz)
○ Compression pressure	Above 28 kg/cm ² (398 psi) at 200rpm
○ Dry weight	Approx. 1,650 kg (3,638 lb)
○ Dimension (LxWxH)	1,719 x 1,389 x 1,305 mm (67.7 x 54.7 x 50.4 in.)
○ Rotation	Counter clockwise viewed from Flywheel
○ Fly wheel housing	SAE NO.1
○ Fly wheel	Clutch NO.14

MECHANISM

○ Type	Over head valve
○ Number of valve	Intake 2, exhaust 2 per cylinder
○ Valve lashes at cold	Intake 0.4mm (0.0157 in.) Exhaust 0.5mm (0.0197 in.)

VALVE TIMING

	Opening	Close
○ Intake valve	24 deg. BTDC	30 deg. ABDC
○ Exhaust valve	59 deg. BBDC	21 deg. ATDC

FUEL CONSUMPTION

○ Prime Power (lit/hr)	1,500 rpm	1,800 rpm
25%	38.0	46.4
50%	73.5	85.5
75%	109.8	127.6
100%	148.5	175.1
○ Standby Power (lit/h)	1,500 rpm	1,800 rpm
25%	40.6	49.2
50%	78.7	92.4
75%	118.8	137.8
100%	160.4	191.7

FUEL SYSTEM

○ Injection pump	Bosch in-line "P" type
○ Governor	Electric type
○ Feed pump	Mechanical type
○ Injection nozzle	Multi hole type
○ Opening pressure	285 kg/cm ² (4,054 psi)
○ Fuel filter	Full flow, cartridge type
○ Used fuel	Diesel fuel oil

LUBRICATION SYSTEM

○ Lub. Method	Fully forced pressure feed type
○ Oil pump	Gear type driven by crankshaft
○ Oil filter	Full flow, cartridge type
○ Oil pan capacity	High level 40 liters (10.6 gal.) Low level 33 liters (8.7 gal.)
○ Angularity limit	Front down 20 deg. Front up 20 deg. Side to side 15 deg.
○ Lub. Oil	Refer to Operation Manual

COOLING SYSTEM

- Cooling method Fresh water forced circulation
- Water capacity 23 liters (6.07 gal.)
(engine only)
- Pressure system Max. 0.9 kg/cm² (12.8 psi)
- Water pump Centrifugal type driven by belt
- Water pump Capacity 508 liters (134.2 GPM)/min
at 1,800 rpm (engine only)
- Thermostat Wax – pellet type
Opening temp. 71°C
Full open temp. 85°C
- Cooling fan Blower type, plastic
915 mm diameter, 7 blade

ELECTRICAL SYSTEM

- Charging generator 24V x 45A alternator
- Voltage regulator Built-in type IC regulator
- Starting motor 24V x 7.0kW
- Battery Voltage 24V
- Battery Capacity 200 AH (recommended)
- Starting aid (Option) Block heater

ENGINEERING DATA

- | | |
|---------------------------------|--|
| ○ Water flow | 433 liters/min @1,500 rpm |
| ○ Heat rejection to coolant | 59.6 kcal/sec @1,500 rpm |
| ○ Heat rejection to CAC | 24.2 kcal/sec @1,500 rpm |
| ○ Air flow | 41.1 m ³ /min @1,500 rpm |
| ○ Exhaust gas flow | 111.3 m ³ /min @1,500 rpm |
| ○ Exhaust gas temp. | 536 °C @1,500 rpm |
| <hr/> | |
| ○ Water flow | 508 liters/min @1,800 rpm |
| ○ Heat rejection to coolant | 66.8 kcal/sec @1,800 rpm |
| ○ Heat rejection to CAC | 39.1 kcal/sec @1,800 rpm |
| ○ Air flow | 52.5 m ³ /min @1,800 rpm |
| ○ Exhaust gas flow | 138.4 m ³ /min @1,800 rpm |
| ○ Exhaust gas temp. | 561 °C @1,800 rpm |
| <hr/> | |
| ○ Max. permissible restrictions | |
| - .Intake system | 220 mmH ₂ O initial
635 mmH ₂ O final |
| - .Exhaust system | 600 mmH ₂ O max. |

CONVERSION TABLE

- | | |
|------------------------------------|------------------------------------|
| in. = mm x 0.0394 | lb/ft = N.m x 0.737 |
| PS = kW x 1.3596 | U.S. gal = lit. x 0.264 |
| psi = kg/cm ² x 14.2233 | kW = 0.2388 kcal/s |
| in3 = lit. x 61.02 | lb/PS.h = g/kW.h x 0.00162 |
| hp = PS x 0.98635 | cfm = m ³ /min x 35.336 |
| lb = kg x 2.20462 | |

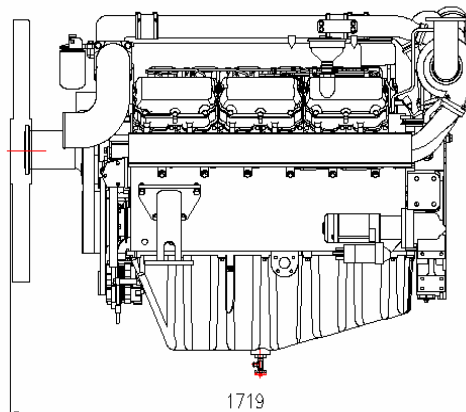
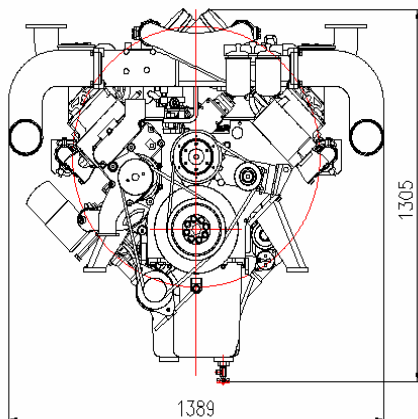

Head office

7-11, Hwasu-Dong, Dong-Gu, Incheon, Korea
TEL : 82-32-211-2222 FAX : 82-32-762-7384

Seoul Office

Doosan Infracore Co. Ltd.,
 22nd Floor, Doosan Tower, 18-12, Euljiro 6-ga, Jung-gu,
 Seoul, Korea.

TEL : 82-2-3398-8521~8535 FAX : 82-2-3398-8509

Web site : www.doosaninfracore.com