

◎ POWER RATING

Engine Speed rev/min	Type of Operation	Engine Power	
		kWm	Ps
1800	Continuous Power	*	*
	Prime Power	307	418
	Standby Power	342	465
1500	Continuous Power	*	*
	Prime Power	265	360
	Standby Power	294	400

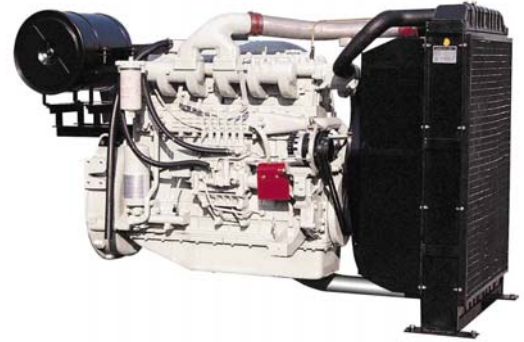

Note : -. The engine performance corresponds to ISO 3046, BS 5514 and DIN 6271.

-. Ratings are based on ISO 8528.

→ **Prime power** available at variable load. The permissible average power out put (during 24h period) shall not exceed 70% of the prime power rating.

→ **Standby power** available in the event of a main power network failure. No overload is permitted.

◎ MECHANICAL SYSTEM

○ Engine Model	P126TI- II
○ Engine Type	In-line 4 cycle, water cooled Turbo charged & intercooled (air to air)
○ Combustion type	Direct injection
○ Cylinder Type	Replaceable dry liner
○ Number of cylinders	6
○ Bore x stroke	123(4.84) x 155(6.1) mm(in.)
○ Displacement	11.051(674.5) lit.(in ³)
○ Compression ratio	17 : 1
○ Firing order	1-5-3-6-2-4
○ Injection timing	16° BTDC
○ Compression pressure	Above 28 kg/cm ² (398 psi) at 200rpm
○ Dry weight	Approx. 910 kg (2,006 lb)
○ Dimension (LxWxH)	1,383 x 870 x 1,207 mm (54.4 x 34.3 x 47.5 in.)
○ Rotation	Counter clockwise viewed from Flywheel
○ Fly wheel housing	SAE NO.1
○ Fly wheel	Clutch NO.14

◎ MECHANISM

○ Type	Over head valve
○ Number of valve	Intake 1, exhaust 1 per cylinder
○ Valve lashes at cold	Intake 0.30mm (0.0118 in.) Exhaust 0.30mm (0.0118 in.)

◎ VALVE TIMING

	Opening	Close
○ Intake valve	18 deg. BTDC	34 deg. ABDC
○ Exhaust valve	46 deg. BBDC	14 deg. ATDC

◎ FUEL CONSUMPTION

○ Prime Power (lit/hr)	1,500 rpm	1,800 rpm
25%	16.9	20.6
50%	31.3	37
75%	47	56
100%	63.1	73.8
○ Standby Power (lit/h)	1,500 rpm	1,800 rpm
25%	18.3	22.2
50%	34.9	41.4
75%	51.6	61.5
100%	77.6	89.5

◎ FUEL SYSTEM

○ Injection pump	Zexel in-line "P" type
○ Governor	Electric type
○ Feed pump	Mechanical type
○ Injection nozzle	Multi hole type
○ Opening pressure	220 kg/cm ² (3,129 psi)
○ Fuel filter	Full flow, cartridge type
○ Used fuel	Diesel fuel oil

◎ LUBRICATION SYSTEM

○ Lub. Method	Fully forced pressure feed type
○ Oil pump	Gear type driven by crankshaft
○ Oil filter	Full flow, cartridge type
○ Oil pan capacity	High level 23 liters (6.1 gal.) Low level 20 liters (5.3 gal.)
○ Angularity limit	Front down 25 deg. Front up 25 deg. Side to side 15 deg.
○ Lub. Oil	Refer to Operation Manual

P126TI- II G-DRIVE

◎ COOLING SYSTEM

- Cooling method Fresh water forced circulation
- Water capacity 19 liters (5.02 gal.)
(engine only)
- Pressure system Max. 0.9 kg/cm² (12.8 psi)
- Water pump Centrifugal type driven by gear
- Water pump Capacity 320 liters (84.5 gal.)/min
at 1,800 rpm (engine)
- Thermostat Wax – pellet type
Opening temp. 71°C
Full open temp. 85°C
- Cooling fan Blower type, plastic
755 mm diameter, 7 blade

◎ ELECTRICAL SYSTEM

- Charging generator 24V x 45A alternator
- Voltage regulator Built-in type IC regulator
- Starting motor 24V x 6.0kW
- Battery Voltage 24V
- Battery Capacity 150 AH (recommended)
- Starting aid (Option) Block heater

◎ ENGINEERING DATA

- Water flow 265 liters/min @1,500 rpm
- Heat rejection to coolant 27.6 kcal/sec @1,500 rpm
- Heat rejection to CAC 8.4 kcal/sec @1,500 rpm
- Air flow 20.1 m³/min @1,500 rpm
- Exhaust gas flow 47.4 m³/min @1,500 rpm
- Exhaust gas temp. 590 °C @1,500 rpm

- Water flow 320 liters/min @1,800 rpm
- Heat rejection to coolant 32.2 kcal/sec @1,800 rpm
- Heat rejection to CAC 14.9 kcal/sec @1,800 rpm
- Air flow 28.2 m³/min @1,800 rpm
- Exhaust gas flow 64.2 m³/min @1,800 rpm
- Exhaust gas temp. 580 °C @1,800 rpm

- Max. permissible restrictions
 - .Intake system 220 mmH₂O initial
635 mmH₂O final
 - .Exhaust system 600 mmH₂O max.

◆ CONVERSION TABLE

- | | |
|------------------------------------|------------------------------------|
| in. = mm x 0.0394 | lb/ft = N.m x 0.737 |
| PS = kW x 1.3596 | U.S. gal = lit. x 0.264 |
| psi = kg/cm ² x 14.2233 | kW = 0.2388 kcal/s |
| in ³ = lit. x 61.02 | lb/PS.h = g/kW.h x 0.00162 |
| hp = PS x 0.98635 | cfm = m ³ /min x 35.336 |
| lb = kg x 2.20462 | |

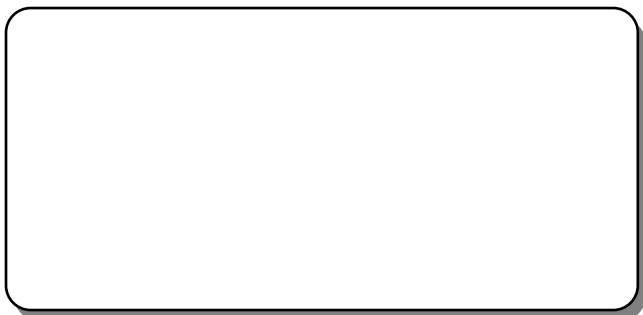
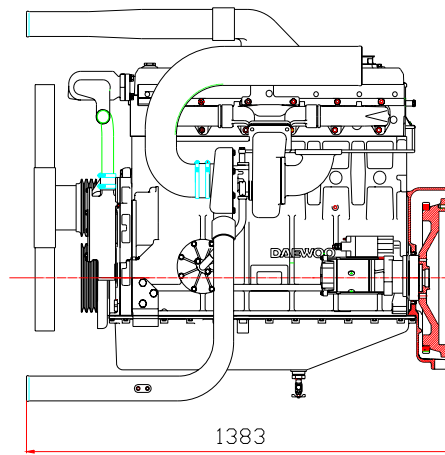
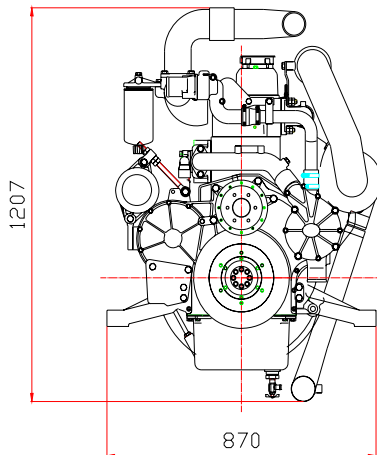

Head office
7-11, Hwasu-Dong, Dong-Gu, Incheon, Korea
TEL : 82-32-760-1437, 1964 FAX : 82-32-760-1964

Seoul Office
Doosan Infracore Co. Ltd.,
22nd Floor, Doosan Tower, 18-12, Euljiro 6-ga, Jung-gu,
Seoul, Korea.
TEL : 82-2-3398-8521~8535 FAX : 82-2-3398-8509
Web site : www.doosaninfracore.com

※ Specifications are subject to change without prior notice