



TM

**Venieri**  
SPA

**10.33B**

**BACKHOE LOADER  
4 WHEEL STEERING**





# **VF10.33B**

## **THE VENIERI 4x4x4**



**VF 10.33B** is the only existing marriage between a 4x4x4 wheeled loader and a 6 meter excavating arm, the rigid backhoe loader guaranteeing the following:

- High transfer speed under all road conditions assured by a 4-ratio automatic selection hydrostatic transmission providing a maximum speed of 38 km/h and identical weight distribution on both axles, enabling you to reach maximum speed even on uneven or sloping ground,
- Unequalled manoeuvrability guaranteed by compact sizing and by two steering axles, which can be varied even during work, plus automatic wheel alignment (2 steering wheels - 4 steering wheels - 'crab' for sideways movements),
- A front excavator unit with the performance of an articulated machine.
- Venieri's undoubted ability to design the best.

## THE SIDE-LOCATED DIESEL ENGINE

On the Venieri backhoe loaders, the centrally/transversally located engine brings the following advantages:

- › Equivalent load distribution on the axles to provide maximum drive and stability under all conditions, including gradients,
- › Lower centre of gravity for better overturning resistance.
- › Total front visibility due to absence of bonnets (engine).
- › A more compact machine.
- › Radiator (with blowing fan) positioned sideways and externally with respect to the frames, to provide excellent cooling of the engine housing.
- › The radiator is always cooled by clean air (avoiding drawing in dust either from the front bucket or from the rear excavator).
- › Maximum access to the machine's hydraulic and mechanical components.

## SIDE-LOCATED RADIATOR WITH BLOWING FAN

In the Venieri VF 10.33B, as the engine is located transversally and as the radiator is at the side, the radiator receives an air flow less polluted by dust, thus increasing heat exchange efficiency. This solution also avoids clogging of the radiator, unwanted suction of material and hot air under the cabin and provides full visibility of the front bucket (thus ensuring greater active and passive safety for the operator).

## UNLOADING DISTANCE

The transverse position of the engine makes it possible to restrict the front dimensions of the frame to create more 'unloading distance'.

## FRONT VISIBILITY

In the Venieri backhoe loaders, the transverse (centrally positioned) engine solution means the front can be compact and free of obstacles, to ensure almost total visibility.

## VENIERI VERSION "Z" BUCKET MOVEMENT

- › Extra breakout force on the bucket blade
- › Bucket self-levelling as follows:  
when the bucket is unloaded at Max height, the arm descent on its own takes the bucket automatically to a parallel to ground position for the next excavation manoeuvre.

## COMFORT AND SAFETY FOR THE OPERATOR

- › Easy to reach driver's seat and large access door.
- › Rear glass panel made mobile by gas jacks that does not exceed the machine overall dimensions even when open.
- › Large front windscreen with generous side and rear glass panels.
- › Generous, practical interior space to allow the driver's seat to rotate.
- › All instruments ergonomically positioned, with great attention to detail.



## ENGINE

Engine: 4 cylinder, turbo-charged, direct injection diesel engine, water cooled, paper dry filter.

Emissioned according to CE 97/68 stage IIIA.

Type .....	Perkins 1104D - 44T
Max power .....	77kW - 105 CV
Rated rpm .....	2200
Net power DIN 70020/6271 .....	70 kW - 95 CV
Net power EEC 80/1269 .....	70 kW - 95 CV
Bore .....	mm 105
Stroke .....	mm 127
Displacement .....	cm <sup>3</sup> 4400

## ELECTRIC SYSTEM

Battery .....	12 Volt
Capacity EN 60095-1 .....	100Ah - 1080 A
Alternator rating .....	540 W
Reverse warning .....	Standard
Wiring according with .....	IP 67 DIN 40050

## TRANSMISSION

Hydrostatic transmission with automatic power regulation and closed circuit with variable displacement pump and motor.

Gearbox with 2 mechanical selections: 2 work speeds (fwd/rev) and 2 road speeds (fwd/rev). Automatic gear shifting for travelling.

	forward	reverse
<b>Work speed</b>		
1 <sup>st</sup> gear km/h	0÷5	0÷5
2 <sup>nd</sup> gear km/h	0÷16	0÷16
<b>Road speed</b>		
1 <sup>st</sup> gear km/h	0÷10	0÷10
2 <sup>nd</sup> gear km/h	0÷38	0÷38

## AXLES

Designed for heavy duties. All-wheel drive.

Self-locking differential with automatic connection/disconnection. Planetary final drives.

Front axle: steering and oscillating up to a total angle of 20°.

Rear axle: steering and fixed to the frame.

## BRAKES

Service: multi-disc oil brakes on all wheels.

Parking: mechanical brake operating on the service brake, manually actuated.

## TYRES

Standard .....	405/70 R 24
Option .....	15.5 R 25 17.5 L 24

## STEERING

Servo-assisted through hydraulic steering with the following system:

- on front wheels for road transport.
- on each wheel inside the working site, where the maximum maneuverability in reduced spaces is required.
- on each wheel for crab steering inside the working site for side displacement.

Inner tyres turning radius .....	mm 2570
Outer tyres turning radius .....	mm 3335
Outer bucket turning radius .....	mm 5600

## HYDRAULIC SYSTEM

Two hydraulic gear pumps, the first controls the shovel-excavator circuit and the second controls the power steering. Modular two-element control valve for the loader, modular six-element control valve for the backhoe.

Double acting hydraulic cylinder.

Hydraulic oil cooling radiator.

Full-flow oil filter on the leakage pipe.

Max flow .....	lt/1'	130
Loader relief valve pressure .....	bar	230
Steering relief valve pressure .....	bar	175
Lift cylinders .....	mm	90x665
Bucket cylinder .....	mm	110x445
Cycle time .....	sec	8,1

### Loader control

Single lever arm-control with 4-position lifting system and with 3-position bucket system.

### Backhoe control

Two levers backhoe control, "cloche" type.

Two hydraulic-control independent stabilizers.

Side traslation with four hydraulic locking devices.

## SERVICE CAPACITIES

Engine .....	lt	8
Front axle .....	lt	10,8
Rear axle .....	lt	10,8
Gear box .....	lt	1,6
Hydraulic circuit .....	lt	134
Brake system .....	lt	0,9
Fuel .....	lt	133
Water cooling .....	lt	18

## TECHNICAL FEATURES

### Loader

Standard bucket capacity .....	m <sup>3</sup>	1,20
Bucket width .....	mm	2350
Breakout force .....	kg	9100

### Backhoe loader

Type .....	VF	4.45C
Standard bucket capacity .....	lt	165
Bucket width .....	mm	500
Dipperstick max penetration capacity .....	kg	4450
Max breakout force on the bucket tip .....	kg	5550
Lifting capacity on the bucket pin up to max height. kg		1500
Rotation .....		180°
A - Max digging depth .....	mm	4800
B - Standard digging depth .....	mm	4400
C - Max digging depth with telescopic (opt.) .....	mm	5800
D - Standard digging depth with telescopic (opt.) .....	mm	5400

## DIMENSIONS AND WEIGHTS

Max lenght in transfer position .....	mm	6000
Max width in transfer position .....	mm	2350
Width across tyres .....	mm	2290
Tracks width .....	mm	1890
Ground clearance .....	mm	450
Standard weight in running order .....	kg	8200
Max weight in running order .....	kg	8800

*The illustrations on the present folder do not necessarily show the product standard version. Data and dimensions described in this folder are not binding. Venieri reserves the right of carrying out possible changes at any time and without previous notice because of its policy of steady development and improvement of the products.*

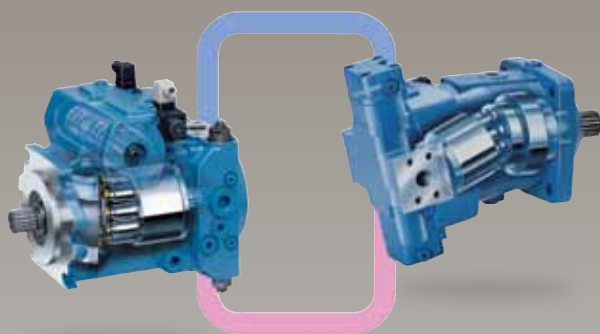

**Rexroth**  
Bosch Group

## **HYDROSTATIC TRANSMISSION**

The advantages of hydrostatic transmission:

- › Full power usage even in lower speed range
- › Maximum traction effort even at lower diesel engine speed
- › Load limiting control of diesel engine
- › Optimum power distribution between drive and hydraulics
- › Very low constant speed movement for special tools
- › Reduced brake wear due to the hydrostatic deceleration
- › Reversing without having to stop the machine
- › Comfortable transfers by using the automatic selection.



 Perkins

## **DIESEL ENGINE**

**Specifications of the new Perkins 1100 series:**

- › Latest generation engine
- › Cross-flow cylinder head and 1100 cc displacement per cylinder for arise:
  - Torque back up
  - Maximum torque
  - 1000 rpm torque.
- › Polluting emissions to standards CE 97/68, stage IIIA
- › Noise level reduced by 3 db(A) (compared to previous version)
- › 500 hour maintenance intervals
- › 2-year total guarantee.

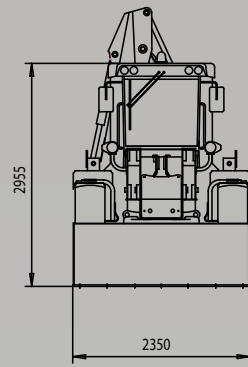
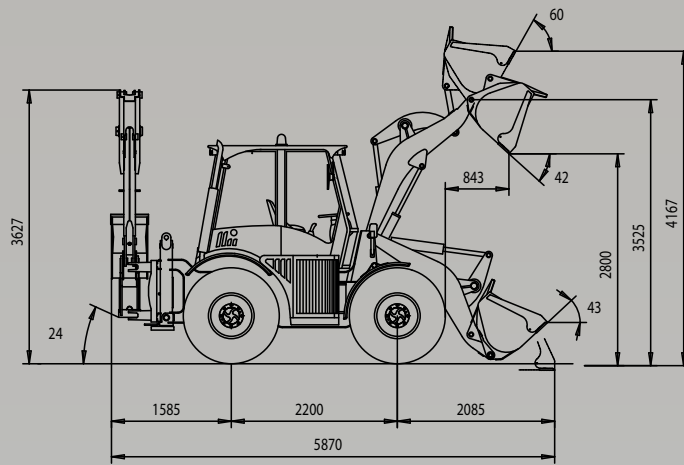

**Loading bucket (kg)**

Static tipping load	5.600
Payload (50%)	2.800

**Loading fork (kg) - centre of gravity 500 mm**

Static tipping load	4.600
Payload EN 474-3 (80%)	3.700
Payload EN 474-3 (60%)	2.700
Payload DIN 24094 (50%)	2.300

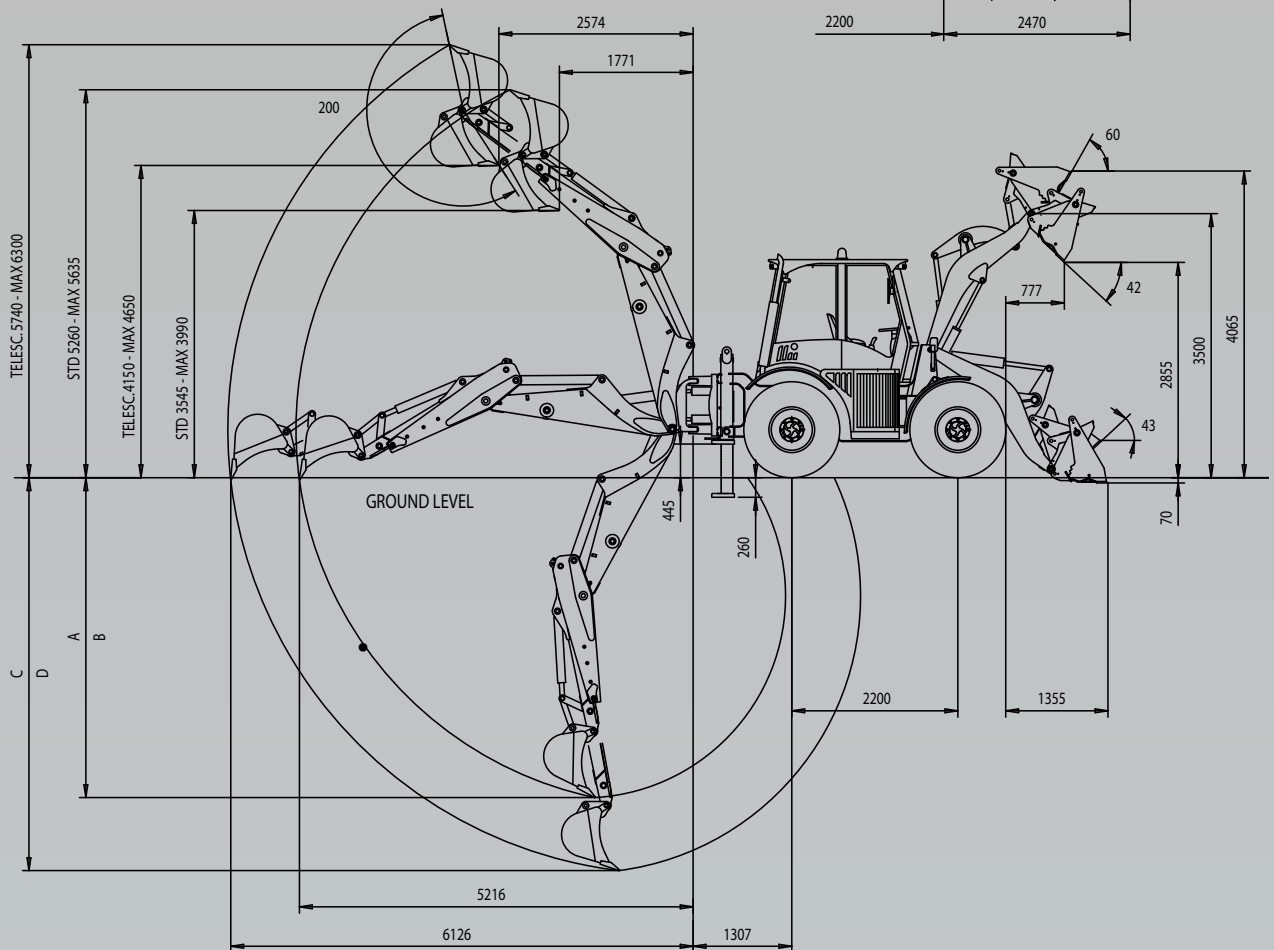
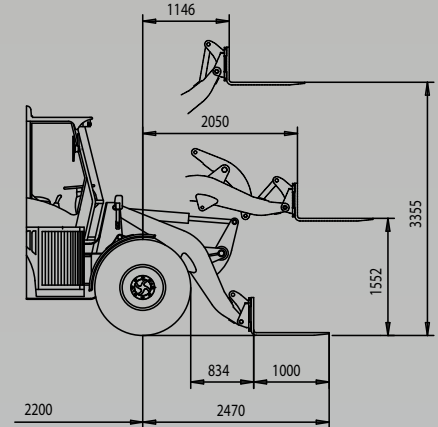

**Verieri**

**10.33B**

**BACKHOE LOADER  
4 WHEEL STEERING**



## STANDARD EQUIPMENT

- › Acoustic warnings
- › Loader bucket with bolted teeth
- › Backhoe bucket
- › ROPS/FOPS cabin, with heating and pressurising system, front and rear windscreen wiper with washer
- › Tool box
- › Spare parts catalogue
- › Safety belt
- › Self-locking proportional differential gear on rear axle
- › Arm and bucket locking safety device
- › Arm locking safety device for rear excavator
- › Visual index for bucket position
- › Working lights
- › Towing hook
- › Sound-proofing
- › Rotating beacon
- › Operation and maintenance manual
- › Fully adjustable seat
- › Side rear-view mirrors
- › Complete dashboard instrumentation

## OPTIONAL EQUIPMENT

### Loader

- › Quick hydraulic or mechanical connection for equipment
- › Side dumping bucket
- › Mixing bucket
- › Multi-purpose bucket
- › Raised dumping bucket
- › Arm with hydraulic shredder
- › Limited Slip self-locking differential on front axle
- › Forward speed reduction device
- › Lifting forks
- › Asphalt and concrete cold planer
- › Snow blower
- › Air conditioning
- › Snow blade or snow plow blade
- › Angle-tilt-dozer blade
- › Hand-operated hydraulic breaker
- › Log forks
- › Front grippers
- › Rotating brush or sweeper
- › Trencher
- › Winch

### Backhoe

- › Quick connection for backhoe buckets
- › Bucket with mechanical ejector
- › Loading or cage clamshell bucket
- › Orange peel buckets
- › Ditch cleaning or digging buckets
- › Backhoe buckets of various width
- › Extending dipper-stick
- › Ripper tooth
- › Side digging boom hydraulically operated
- › Hydraulic breaker
- › Asphalt cutter disk
- › Hydraulic shredder
- › Hydraulic auger
- › Grapples



**VENIERI** SPA  
EARTHMOVING MACHINES

Via Piratello, 106 - 48022 Lugo (RA) ITALY  
Tel. +39 0545 904411 Fax +39 0545 30389  
e-mail: [info@vf-venieri.com](mailto:info@vf-venieri.com) [www.vf-venieri.com](http://www.vf-venieri.com)

### Spare Parts

Tel. +39 0545 904429 Fax +39 0545 24555  
[ricambi@vf-venieri.com](mailto:ricambi@vf-venieri.com)

